



FALCON RIDGE

2515 Bypass Rd. Flemingsburg, KY 41041
606-845-7439

Instructions for Installation and Care of Mahindra Roxor

Full Cab fits Windshield Without Cargo Cover MAH-ROXOR-FC05

Notice: Do not smoke inside the cab or expose the enclosure to direct flames. Cab is Flammable.

1. Be sure to read these instructions thoroughly before opening and installing the enclosure. The installation is best done when the temperature is 70 degrees F. or warmer. The temperature affects the adhesive Velcro, if conditions prevent installing in warmer weather it helps to store the adhesive Velcro at room temperature prior to installation.
2. Carefully open the carton and remove the enclosure on a large flat surface that is clean and free of dirt.
3. Check over the parts included in the carton with the parts list shown below:

	<u>Doors</u>
Adhesive Velcro Hook Strips:	18 each-----3”
“ “ “ “	2 each-----6”
“ “ “ “	2 each-----45”
	<u>Rear Window</u>
“ “ “ “	1 each-----45”
	<u>Top Cap</u>
“ “ “ “	4 each-----6”
Webbing Straps with Velcro	2 each-----60”
	2 each-----25”
Cab Enclosure	4 panels

The cab will be put together using the following parts and in this order.

- 1) Soft Doors
- 2) Rear Window
- 3) Top Cap

Note: You will need to remove the windshield prior to installation of the cab enclosure

SOFT DOORS

1. Begin by placing the 45" adhesive Velcro strip down the back side of the middle vertical bar of the roll cage. The photo below shows how this should look.



2. Next place the 6" adhesive Velcro strips on the front of the roll cage where the windshield bolts on. Place the strip just above the bottom hole making sure you don't cover the holes up. See photo below.

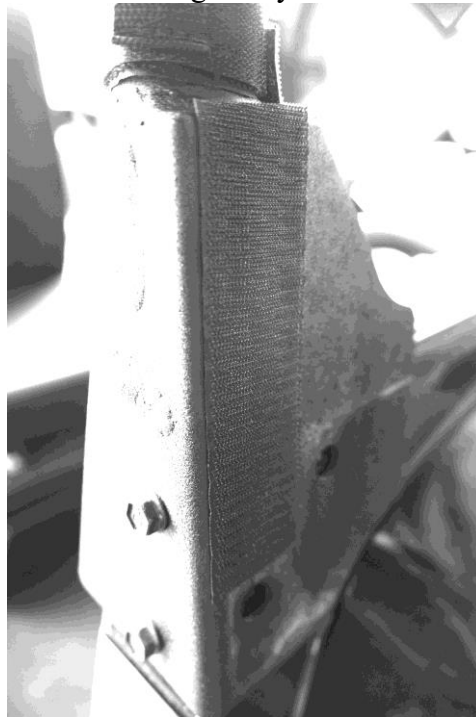

3. Take the door and attach it to the roll cage so the double-sided tab along the back of the door and the 6" tab on the front of the door line up with the adhesive strips you just installed.



4. Now take the 3" adhesive strips and place one on the inside of the roll cage where each of the double-sided Velcro strips are sewn along the edges of the top and front of the door. The following pictures show how this works.

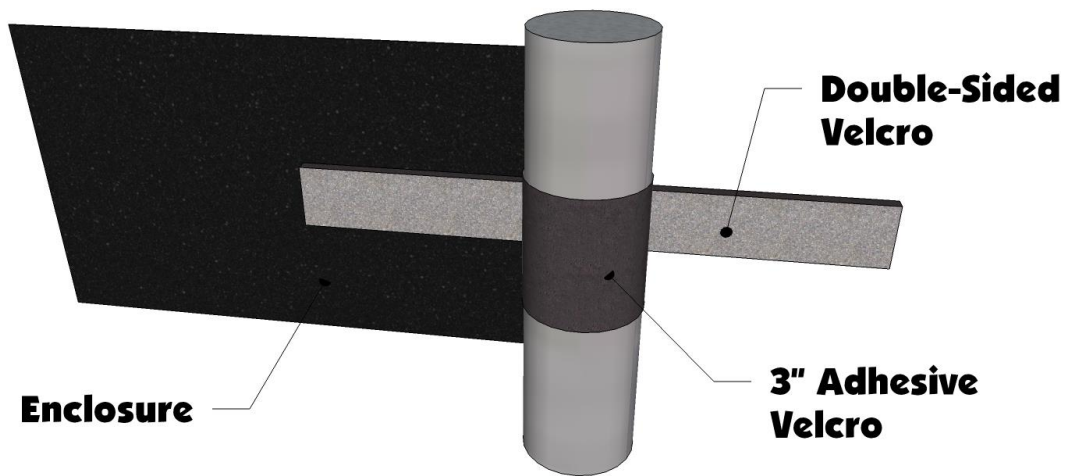

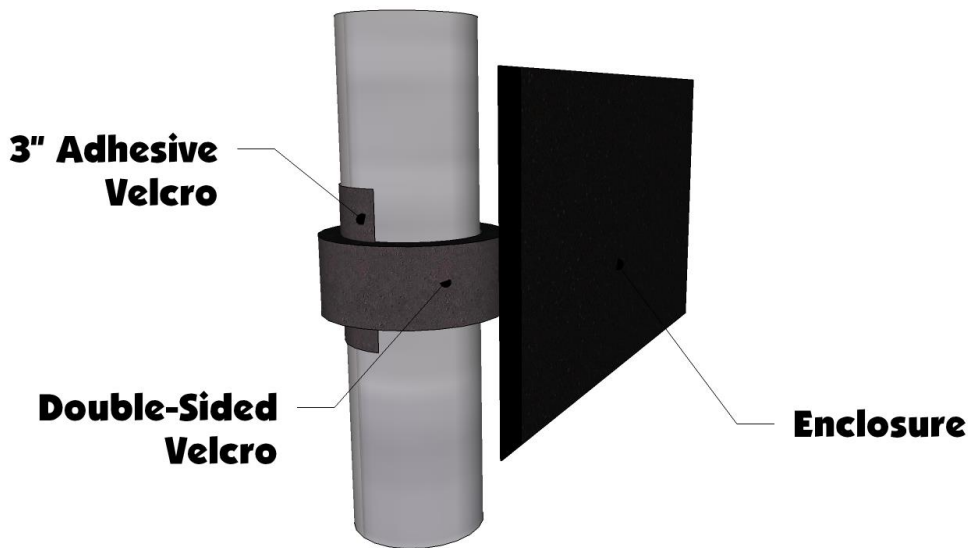

5. Now take the bottom of the door and pull it down so all the magnets are in the proper place.

REAR WINDOW

6. Now take the remaining 45" adhesive Velcro strip and run it across the top of the top rear bar as shown in the photo below.



7. Then place the Rear Window on the window by centering the panel and attach at the top first then the sides will attach to the double-sided tabs of the doors. The bottom of the panel simply attaches to the floor with magnets. See photos below.



TOP CAP

8. The last item to install is the Top Cap. You have been supplied with 4 straps with double-sided Velcro sewn to one end. Take the 6" adhesive Velcro strips and wrap them around the bars at the following locations.

9. In the front wrap the bar just under the windshield clamp with the 6" adhesive Velcro. Then wrap the double-sided Velcro sewn to the end of the short strap around the adhesive Velcro as tight as you can get it. Then run the strap through the buckle in the front corner of the Top Cap. Do not pull it tight yet, just pull it in place. See photo below.



10. The rear of the Top Cap is held in place using the straps that have double-sided Velcro sewn in one end. Take the 6" adhesive Velcro strips and wrap them around the roll cage at the bottom rear of the roll cage just below where the sides and rear panels come together. Now take the end of the strap with the Velcro and wrap it around the bar and Velcro as tight as possible. Then take the other end of the strap and run it through the loop, pulling it tight. The photo below shows what it should look like.

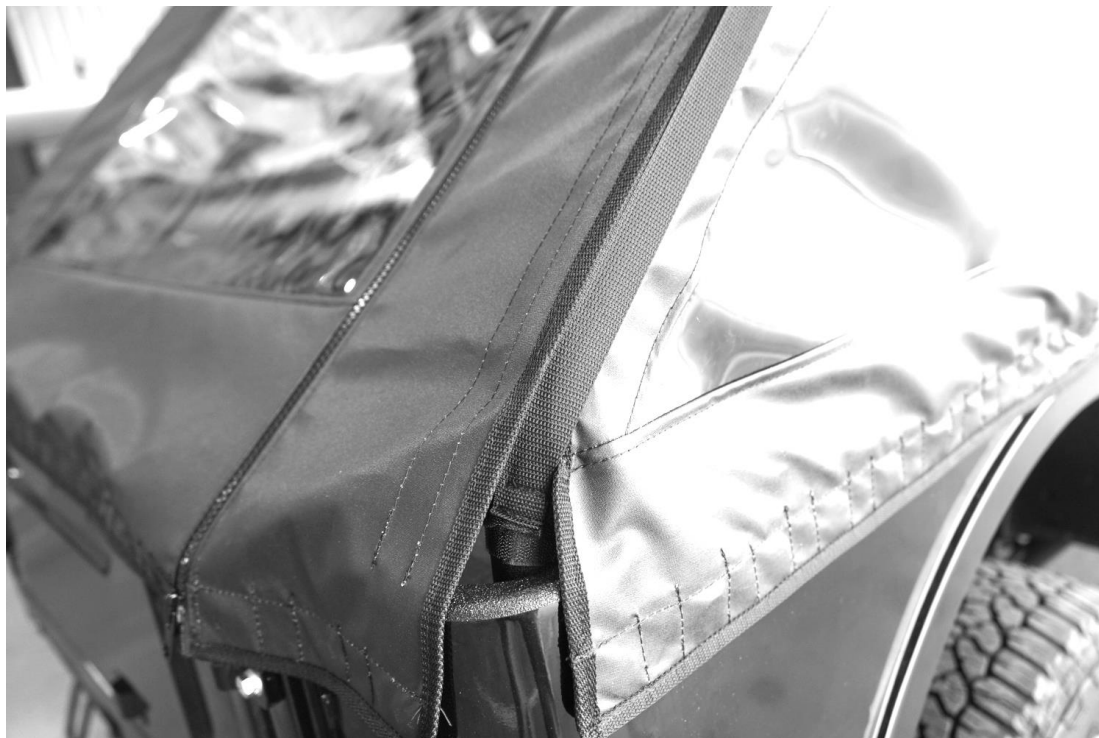

11. Once all the straps are in place run them through the buckles. Pull them tight making sure the top is centered and the side seams line up correctly along the roll cage. The diagram below shows how to lace the webbing through the buckle.



Cleaning and Storage Recommendations:

1. Before removing the Falcon Ridge Cab for storage, make sure it is very clean in order to prevent scratching of the window panels. Clean with a soft rag or sponge using a mild liquid detergent soap and warm water solution. Never rub the windows with a dry cloth or rag! Let the Cab dry thoroughly before attempting to roll for storage.
2. It is important that the Cab be rolled up for storage rather than folding. Folding will cause damage to the windows!!! Carefully roll up the Cab similar to the way it was when it was packed at the factory. On a large, clean and flat surface, fold the doors over the rear panel first, then, interleave the top and

windshield on top of the doors. Begin rolling the Cab into a roll approximately 8 inches in diameter. Put the rolled Cab back into the carton for storage at a normal room temperature. It is best not to expose the Cab to either extreme hot or cold temperatures when storing.

3. A special cleaner conditioner is available from Falcon Ridge that will greatly increase the service life of the Cab Enclosure. In addition, if additional hook and loop sets are needed, they can also be ordered.