

## **Installation & Operations Manual 2 Piece Hood Rack for Polaris Ranger With Pro-Fit Roll Cage**



**Installation information:**

- This product has an installation rating of: **Easy**
- Approximate installation time: **30 Minutes**
- This product is easiest to install with: **2 people**

Light bar sold separately

Seizmik makes Windshields, Doors, Tops, Hood Racks, Brush Guards, and other great accessories for utility vehicles & side x sides. Our products are engineered tough for long life and tested under the harshest of conditions.

Always observe the warnings and precautions in this manual when using your Seizmik products. For best results, carefully follow the instructions in this manual and make no modifications.

Seizmik products are designed, developed and manufactured by Vialink Corp. If you have any questions, comments, need assistance, or are missing parts, please call 1-866-838-3366 between 9:00AM and 5:00PM EST. You can email us at [support@seizmik.com](mailto:support@seizmik.com)

# Parts List

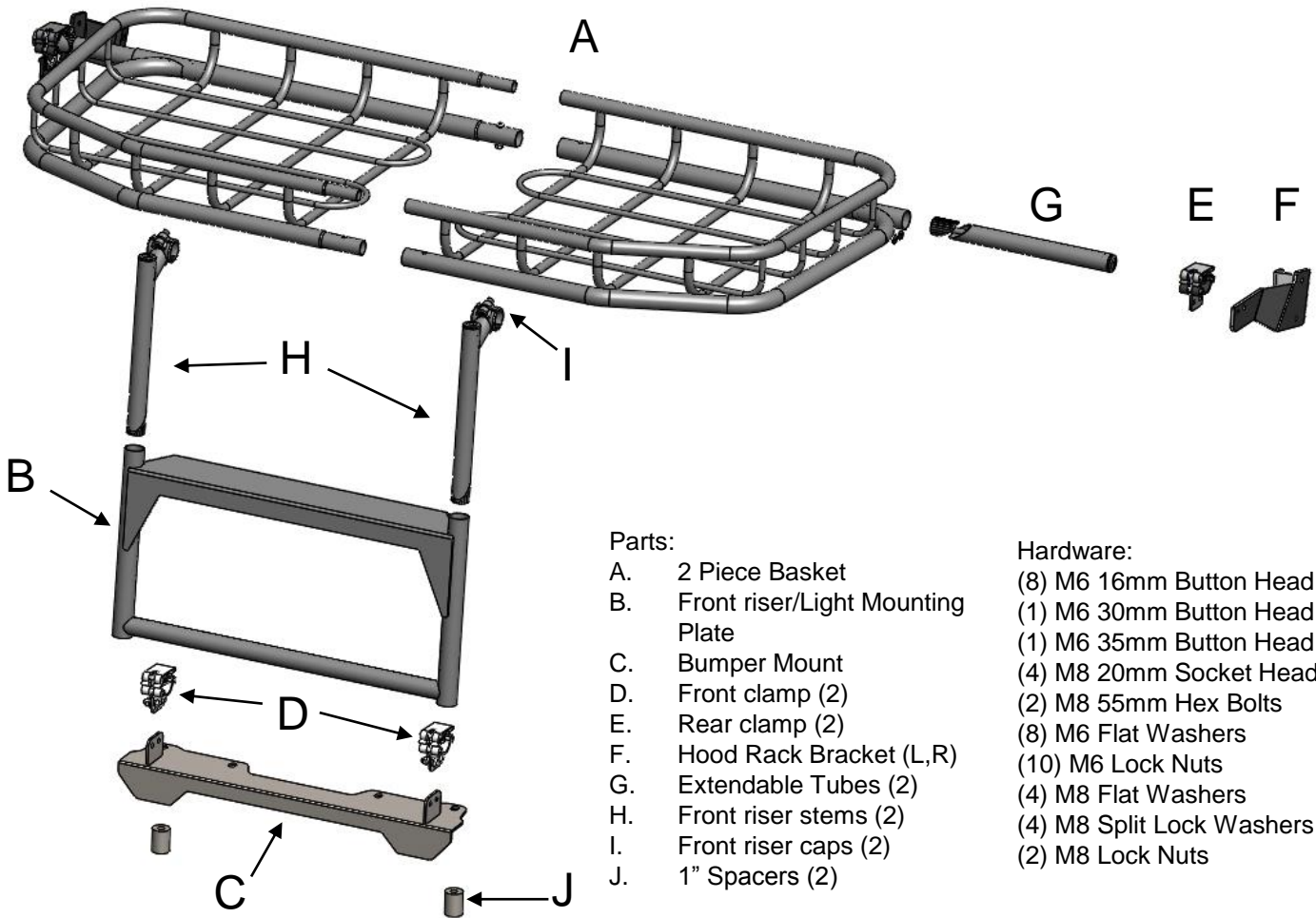

- Parts:
- A. 2 Piece Basket
  - B. Front riser/Light Mounting Plate
  - C. Bumper Mount
  - D. Front clamp (2)
  - E. Rear clamp (2)
  - F. Hood Rack Bracket (L,R)
  - G. Extendable Tubes (2)
  - H. Front riser stems (2)
  - I. Front riser caps (2)
  - J. 1" Spacers (2)

- Hardware:
- (8) M6 16mm Button Head Bolts
  - (1) M6 30mm Button Head Bolt
  - (1) M6 35mm Button Head Bolt
  - (4) M8 20mm Socket Head Bolts
  - (2) M8 55mm Hex Bolts
  - (8) M6 Flat Washers
  - (10) M6 Lock Nuts
  - (4) M8 Flat Washers
  - (4) M8 Split Lock Washers
  - (2) M8 Lock Nuts

## Basket Assembly

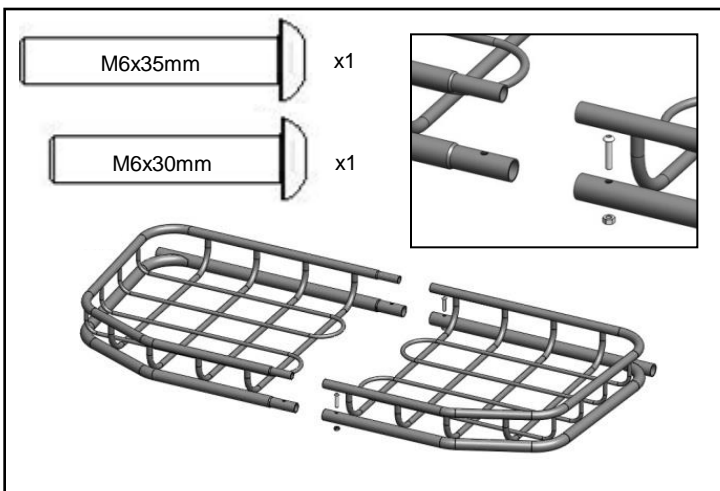

1. Assemble two sides of rack. Secure the back of the rack with a single M6 35mm Socket Head bolt and lock nut. Secure the front of the rack with a single M6 30mm Socket Head bolt and lock nut.

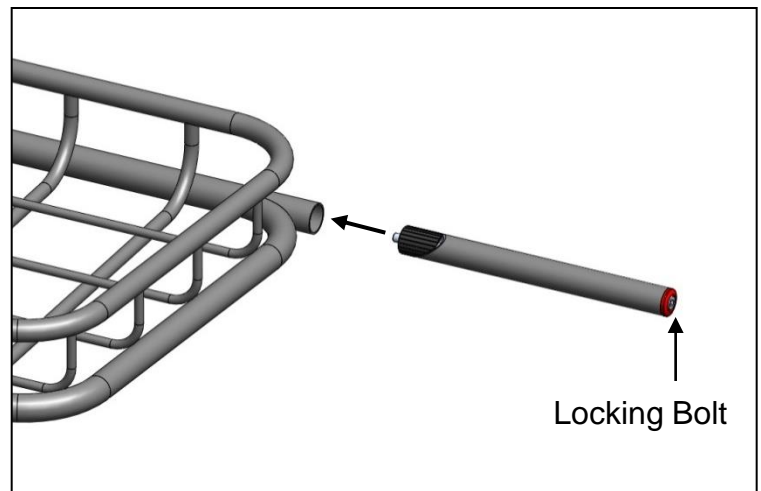

2. Insert the two (G) Extendable Tubes in the ends of the hood rack. Tighten bolts at the ends with a 6mm Hex key just enough to hold tube in place. You will tighten after final assembly.

## Important Notes

### Clamp Orientation and adjustment

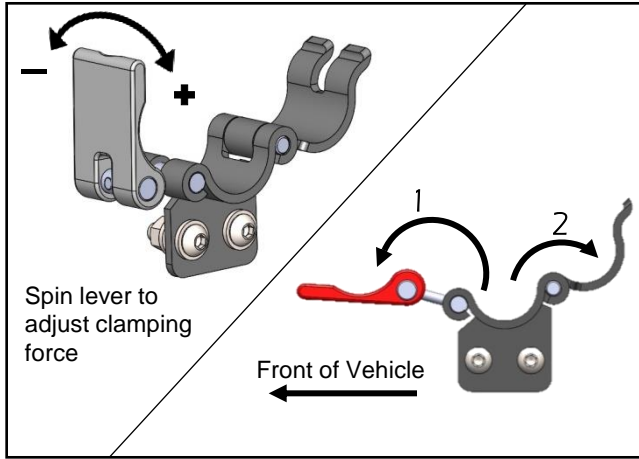

To open a clamp, lift up on both levers in the order above. Orient all clamps so the first clamp lever opens towards the front of the vehicle. To increase clamping force, spin the lever clockwise; to decrease the clamping force, spin the lever counter-clockwise before locking.



4. Set the two 1" spacers on the bumper holes. Then set the mount on the bumper and attach using (2) M8 x 55mm Hex Bolts, two 1" Spacers (J), six washers, and two M8 Lock Nuts. The order is shown in the picture above.

## Bumper Mount and Front Clamp Assembly

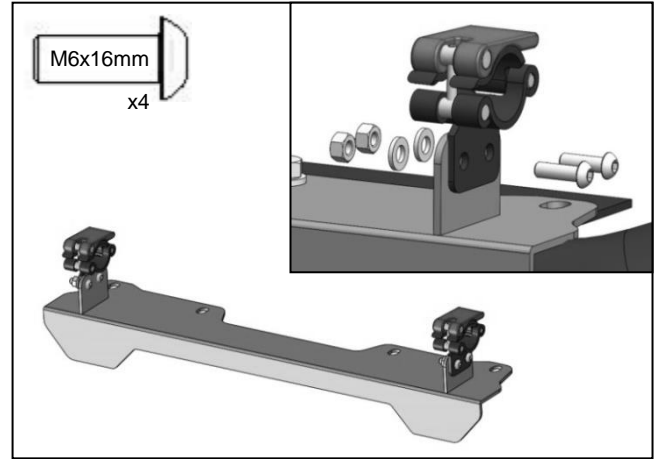

3. Attach the two front clamps (D) to the bumper mount (C) using (4) M6 x 16mm bolts, (2) washers and (4) locknuts. Make sure all clamp levers open away from the vehicle.

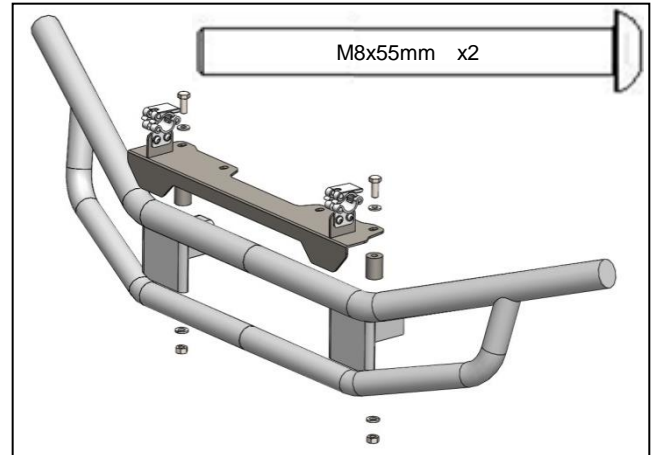

## Rear Bracket and Clamp Assembly

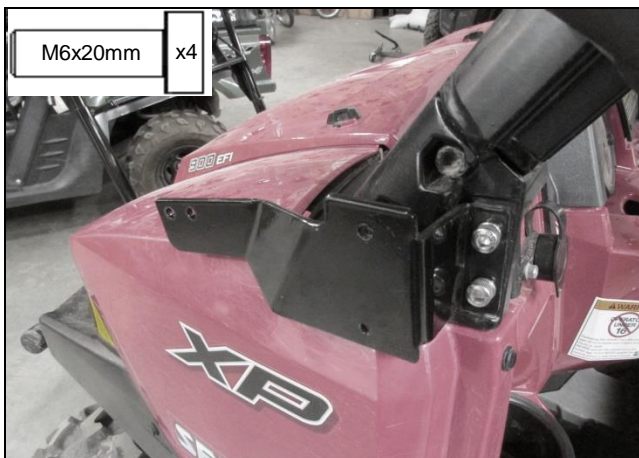

5 Attach the hood rack brackets (F) to the sides of the roll cage using (4) M8 x 20mm socket head bolts as shown above.

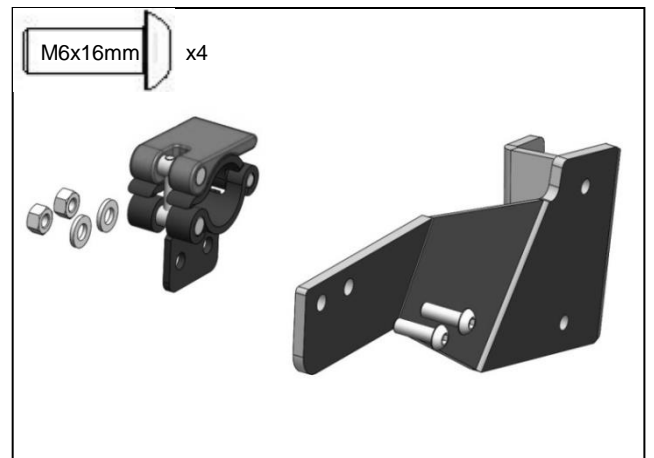

6. Attach the two Rear Clamps (E) To the Hood Rack Bracket (F) with two M6 x 16mm socket head bolts, 4 washers and 2 nuts. The clamp lever should open towards the front of the vehicle.

## Riser Assembly

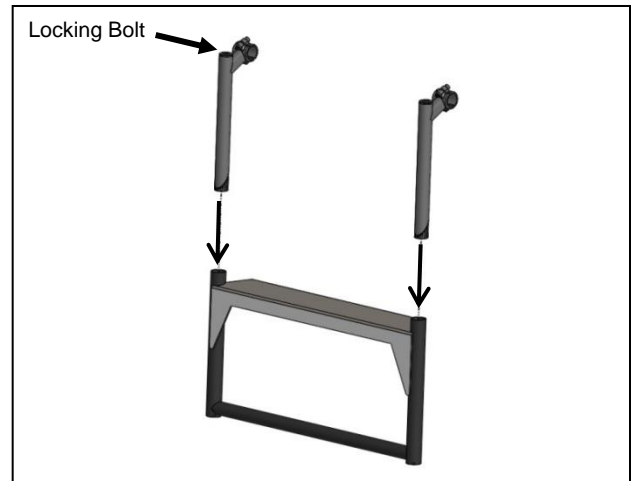
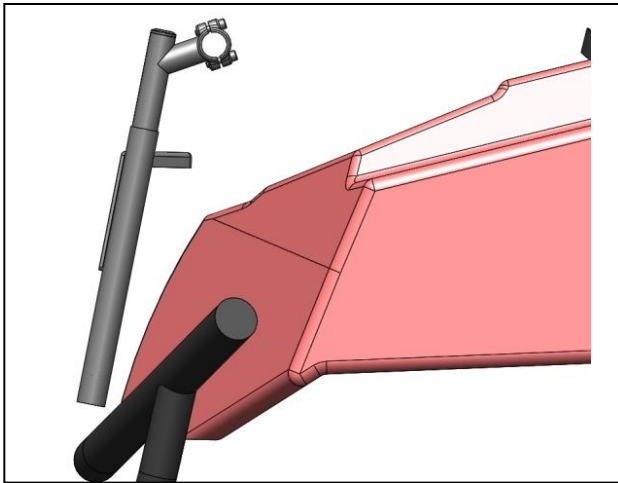

7. Note the riser orientation shown above. Insert the 2 Front riser stems (H) into the front riser/light mounting plate a few inches in. Tighten the locking bolt at the top of the tube with allen wrench just enough to hold the riser stems in place. You will tighten after final assembly.

## Basket Installation and Adjustment

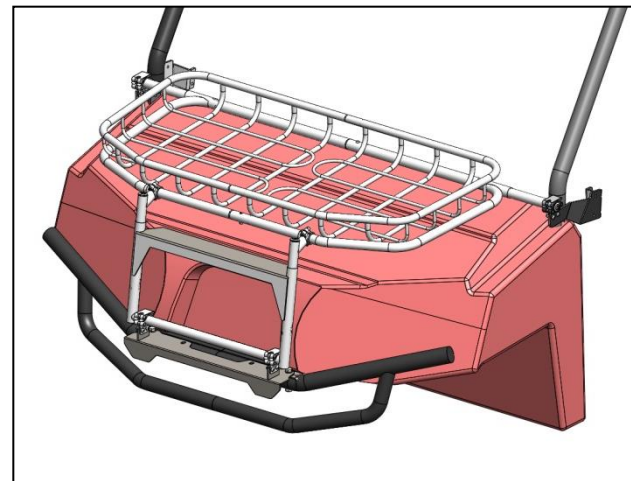
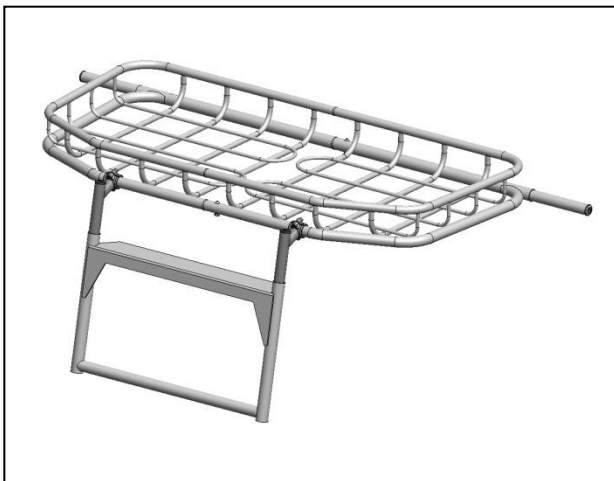

8. Attach the riser assembly to the front of the hood rack and bolt the two front riser caps in place. Snug the cap bolts, but keep them loose enough to allow rotation. Make sure all 4 clamps are open, then set the rack in place.

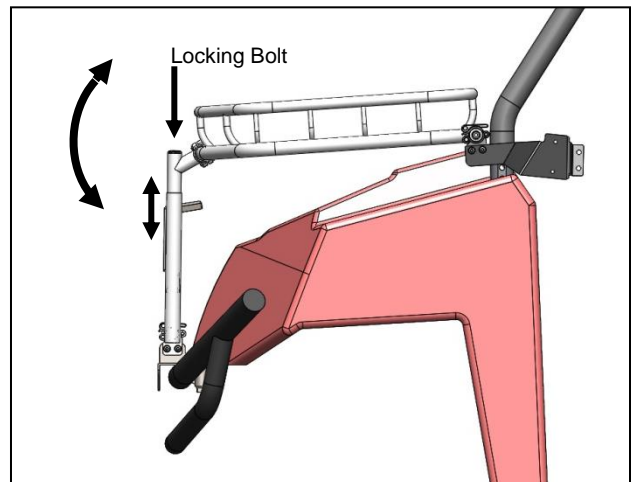
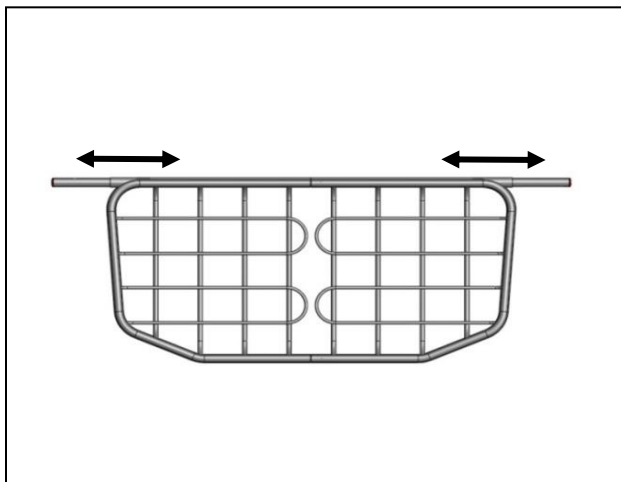

9. Adjust the width of the extendable tubes (G) so they stick out just past the clamps. The hood rack angle can be adjusted by loosening the bolt on the front riser stems and lifting up or pushing down on the front of the rack. Adjust clamps and brackets as necessary, then tighten all bolts. We recommend no more than 5% of slope to the hood rack.

## Attaching Other Accessories to your hood rack.



Lights or a light bar can be attached to the hood rack by drilling holes in the light mounting plate. We recommend our 13" 60 Watt Seizmik Light Bar with 5,400 Lumen output. Part Number #12037

**Congratulations** – You have now finished the installation of your Seizmik Hood Rack.

**How to get Help** - If you have any questions, comments, need assistance, or are missing parts, please call 1-866-838-3366 between 9:00AM and 5:00PM EST. You can email us at [support@seizmik.com](mailto:support@seizmik.com), visit [www.seizmik.com](http://www.seizmik.com) to download installation guides and product info, or contact your powersports dealer where you purchased your Seizmik product if you need additional assistance.